

Straight Contact Pins

- 8 mm to 80 mm length
- Loose pins or bandoliered
- Choice of platings available
- Choice of base materials available
- Optional Retention Feature
- Custom versions available

Physical

Contact Metal

Standard Material: CuNi18Zn20 to DIN 17663 (FB18) (Nickel Silver)
Other base materials options available

Strap / Bandoleer Metal

Standard Material: Brass

Plating Options

0,25µm Gold (all over)

Underplating: 1,27µm (50µ") Ni
Interface Area: 0,25µm (10µ") AuCo 0,2 minimum
Solder Tails: 0,25µm (10µ") AuCo 0,2 minimum

0,76µm Gold (Selective)

(Bandoleered pins only)

Underplating: 1,27µm (50µ") Ni
Interface Area: 0,76µm (30µ") AuCo 0,2 minimum
Solder Tails: 2,54µm (100µ") Sn100

Lead Free

Underplating: 1,27µm (50µ") Ni
Interface Area: 2,54µm (100µ") Sn100
Solder Tails: 2,54µm (100µ") Sn100

Other plating options available

Electrical

Current Rating: 2,5 A
Withstanding Voltage: 1500 V DC at sea level

Environmental

Temperature Rating: -40 °C to +120 °C

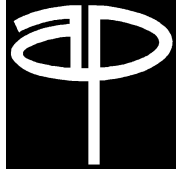

Series 0,635

Ordering Information

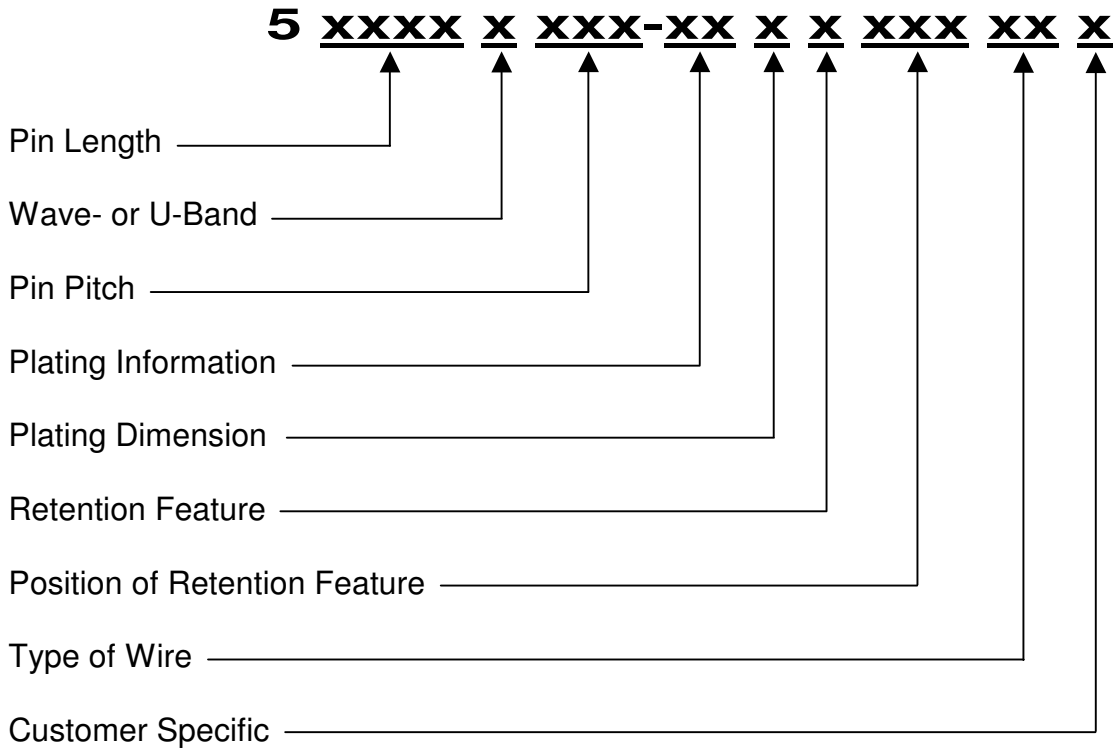

Engineering Note:

The information presented in this datasheet is accurate to the best of our knowledge.

Due to ongoing efforts to advance design and material performance, this information is subject to change without notice.